TECHNICAL DESCRIPTION OF WESTERN CO. PV STREET-LAMP

SSL24B-W-E



Western CO. PV street-lamp must have:

- No. 01 PV module (NOT INCLUDED) to be properly dimensioned according to the place / latitude of installation and the requested hours of lamp activation per night;
- No. 01 control electronics with light sensor working – time bands – through sensor of PV module with programmable turning off with timer by n° 4 internal switches;
- No. 01 electronics for LED with flux reduction;
- No. 02 12V 100Ah Pb sealed batteries without maintenance (tot. 200Ah 12V);
- No. 01 UV resistant kit of cables;
- No. 01 stainless steel (INOX) top-of-pole mounting structure with drawer for batteries having lateral opening that can be regulated with different inclination tilts;
- No. 01 street LED luminaire;
- No. 01 lamp-bracket;
- No. 01 galvanized tapered pole 7 meters over ground(h tot 7.8m, diameter at the bottom =168mm, diameter on the top= 102mm, metal thickness = 4mm). NOT INCLUDED.

System description:

The PV street-lamp has been dimensioned to work with programmed turning ON up to 12 hours per night with reduced luminous flux and autonomy of 4 days in case of NO SUN condition.

The electronic circuit, with nominal voltage 12/24V (autodetect), has the function of charge regulator with MPPT technology. It makes the research of the point of the module's maximum power (MPPT) and it allows the regulation of activation hours according to the produced energy (auto-management algorithm).

The control electronics of the PV street-lamp must have on the same printed circuit board the possibility to connect a hardware module for system control and setting through a **Radio or GSM communication module**.

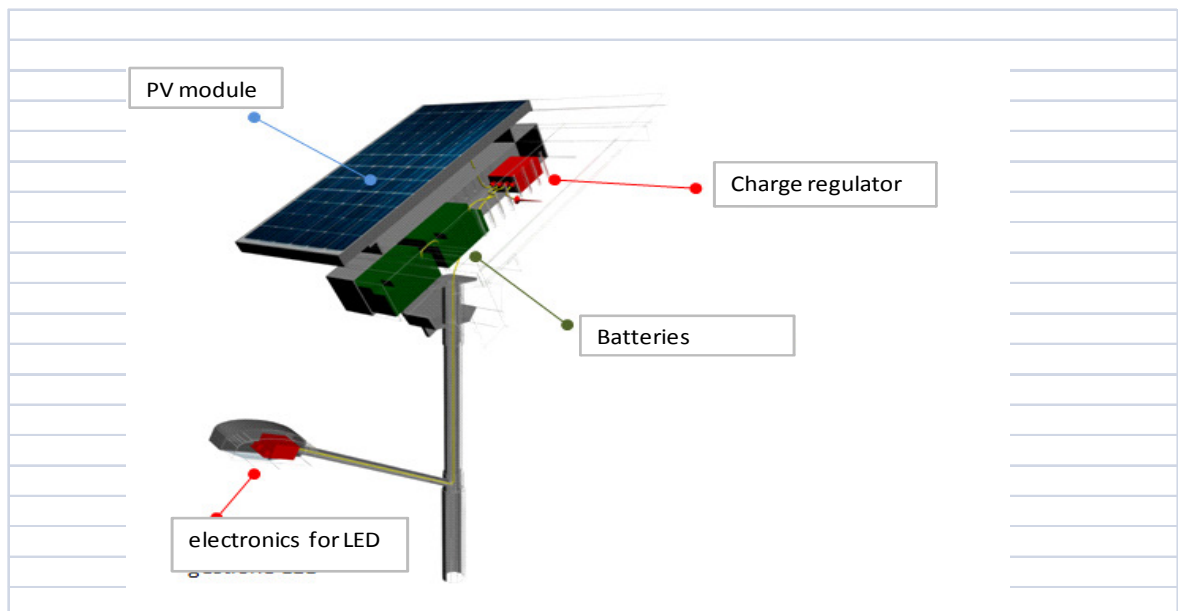

Technical description of the single components

1. Western Co. electronics:

SPB-LB-V2 charge regulator has been planned to be used in off-grid PV lighting systems; in fact, thanks to its IP65 metal case, it is indicated for use in environments exposed to the elements. SPB-LB has got a very efficient recharge circuit with an algorithm of search of the maximum PV modules' power (MPPT); it has got a wide input range (up to 100V) so to adapt the different types of photovoltaic modules. It is suitable for 12V and 24V systems (auto detect) both for sealed and flooded lead acid batteries and it can manage a max PV power of respectively 225W and 450W. The recharge is compensated in temperature (external sensor). SPB-LB manages intelligently an installation with remote battery (at the bottom of the pole~10mt) without using additional connections and it has got many protections: battery polarity inversion, overload, overvoltage, over temperature, low battery. The latter threshold is selectable for a use of the battery bank with depth of discharge (DoD) of 30% or 70%.

SPB-LB manages an output for a load with currents up to 8A able to drive our SOX-E ballasts (for LPS lamps) and the drivers for LED lamps. Another output called DIMMER is also dedicated for our products in order to handle even the lamp flux reduction. This feature allows to reduce consumptions during the hours where there is not a need for maximum lighting. Load activation and flux reduction are programmable through dip-switches as shown in the table.

Day/night detection is executed according to the PV module voltage; therefore it is not necessary to connect further sensors to the regulator. The choice to use terminals for quick connection (no screws model "cage clamp") for connections is dictated by the simplicity and reliability of the contact that no longer depends on screw tightening. The wide box assures an easy cabling thanks also to the protective barriers for the most delicate electronic components.

Status LED, switches and screen printing indications facilitate the system configuration, the working analysis and diagnostics.

- Code SPB-LB-V2 Western Co.
- ISO 9001:2008 certified manufacturer
- MPPT charge
- Wide range of input voltage of the PV module (up to 100V)
- Max power of PV module: 225W @ 12V and 450W @ 24V
- Integrated blocking diode
- 12/24V autodetect
- Switch for battery selection: sealed, GEL or flooded lead acid.
- Switch for selection of battery distance: 1 or 10 meters.
- Switch for setting depth of discharge (DoD) 30% or 70%.
- Recharge of battery compensated in temperature.
- Integrated light sensor (through PV module).
- Possible load activation with flux reduction.
- Switch to program the hours of load activation.
- Auto management.
- Protection for battery polarity inversion.
- Over temperature protection.
- Overload protection.
- Low battery protection.
- LEDs for the following indications: 12/24V; on/off load; on/off flux reduction; current from PV; protections.
- IP65 metal box for outdoor application.



2. PV modules (not included)

The PV modules must be properly dimensioned according to the place / latitude of installation and the requested hours of lamp activation per night.



3. Top-of-pole mounting structure

- Western Co. code **WTP2.01BT1**
 - Stainless steel structure.
 - Box with clefts for aeration.
 - Box with side opening.
 - Side door that can be opened with blocking.
 - Box for batteries and electronics. The box must have the possibility to be inclined together with the PV modules.
 - Adjustable articulation for the inclination of PV modules.
 - Fixing for pole having diameter of 102mm with blocking screws.
- inclinabile insieme ai pannelli fotovoltaici



4. Kit of supports

- To be evaluated according to the used PV module's dimensions;
- **Stainless steel** structure



5. Lamp-bracket

- Western Co. code **BZ100/60T**;
- Steel lamp-bracket with diameter 60mm and length 1000mm with tilt 20° in comparison with the horizontal plane;
- Joint to pole - diameter 102mm – soldered to the lamp-bracket;
- Clefts for cables' passage between joint and lamp-bracket;
- Hot-galvanization.



6. Pole

- Hot-galvanized tapered pole - 7 meters over ground code **RDI7800/4**
- H.tot =A40 7.8m
- Diameter at the bottom =168mm
- Diameter on the top = 102mm
- Metal thickness = 4mm

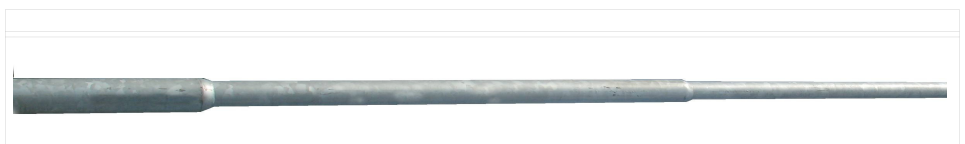



7. Batteries / Accumulators

Batteries must have a nominal voltage of 12V - see features below indicated.

- Voltage 12V
- Capacity 100 Ah in C20
- Pb sealed AGM/VRLA without maintenance
- Low auto-discharge
- For cyclic use of charge and discharge
- Dimensions = 329 x 172 x 211 (mm)
- Weight = 32,80 Kg



8. Kit of cables

- Code **K.CAVI/SSL/UV**
- UV resistant kit of cables for outdoor applications
- Cables for PV modules
- Cables with terminals for batteries



9. WL24 - Luminaire 24LED 24W 12/24VDC 310mA

LED lighting luminaire suitable for bracket or top-pole installation.

The supporting structure of the luminaire, which acts as a heat sink too, is made of extruded aluminium alloy EN AW 6060 T5 EN - T6 state, thickness 6mm, dim. 380x300mm, height 79mm. It is made up of a suitable number of fins exchanging the heat produced by the lighting body with the external environment in order to keep the LEDs' junction temperature at a value that ensures a life longer than 50,000 hours LM70 at 25°C ambient temperature (critical failures included). The anodising treatment is able to ensure resistance to the external environment and promotes heat dissipation. The perfectly flat lower section of the frame is used to secure the side caps. The side caps are made of die-cast aluminum - alloy EN 46100 - epoxy enamelled, after phosphodegreasing treatment (chromium-free) and they are coupled with the body by silicone sealant and screws.

Universal attack to bracket or top-pole made of hot galvanized and painted steel \varnothing 60 mm. Adjustable tilting system which allows an inclination of 0° / -5° / -10° / -30° for bracket installation and of 0° for top-pole installation.

EPDM gasket applied on proper housing obtained from the body and from the side caps. The closing screen is in tempered high transparency flat glass - thickness 4mm with decorative serigraphy; it is fixed on the apparatus body by 4 glass-stop accessories made of die-cast aluminum - alloy EN 46100 - epoxy glazed after phosphodegreasing treatment (chromium-free) and screws. The screen can be easily removed to allow the access to wiring compartment.

The color of the side caps, of the glass-stop and of the attack is: "starry silver". The luminaire has an interior air exchange filter.

Asymmetric street optics composed of n. 2 modules with 12 LED for a total of 24 LED.

Luminaire luminous flux: 1850 lm.

The photometric measure complies with UNI EN 11356.

"Cut-off" photometric emission in compliance with regional laws for light pollution and with UNI EN 13201.

The optical system is composed of single lenses, one for each LED, with high optical efficiency (about 92%) made of polymethylmethacrylate (PMMA).



9. WL24 - Luminaire 24LED 24W 12/24VDC 310mA

Luminous source constituted of high efficiency LED (102 lm/W – $I_f=350\text{mA}$ – $T_j=T_{amb}=25^\circ\text{C}$) with 4500K color temperature and CRI 70. The LEDs are mounted on printed circuit boards manufactured with a layer of aluminum support, ceramic insulation layer and copper conductive layer, total thickness of 1,6 mm.

Between the dissipating part and the LED circuit there is a layer of thermo-conductive material so to improve the thermal continuity between the parties.

LED 5mm – 15° blue color with decorative function installed in the street side cap.

Power supply composed of n. 1 electronic LED Driver with 2 high-efficiency channels (92% typical) - Class of Insulation III, entirely located inside the wiring compartment, that has to ensure the continuity of the LED modules' power supplying, fixed with screws on housing obtained on the luminaire extruded body and connected to LED modules through cables fixed on the output terminal. 12/24 VDC supplying voltage, constant supplying current of LED of 310mA to obtain a total consumption of the luminaire of 24W (including the power supply efficiency) at full flux and a consequent luminaire luminous efficiency of 77,1 lm/W. Thermal protection, overload / short-circuit and overvoltage protections.

Possibility to make the luminaire work at reduced flux of 30% according to the settings on the charge regulator of the PV street-lamp.

Connection to the PV charge regulator by H07RN-F 3x1.5 mmq. neoprene black cable (+Vin, -Vin, Dimmer) integrated in the apparatus and directly fixed on the input terminals of the power supply.

Luminaire input fixing (pole side cap) by M16x1.5 mm white nylon cablegland BM-41L IP68.

Other features:

Luminaire dimensions: 300 x 446 mm.

Luminaire height: 84mm.

Protection degree of optical and wiring compartment: IP65.

Weight: 10,35kg.

Lateral surface exposed to the wind: 0,05 m².

Plant surface exposed to the wind: 0,15 m².

Insulation class: III (SELV).

Warranty: 2 years



LIGHTING PERFORMANCES - EN 13201 RULE COMPLIANCE

Ta	Ambient temperature	[°C]	25
MF	Maintenance factor	[%]	80
T	Luminaire tilt angle	[°]	0
S	Overhang	[mt]	0
L	Road width	[mt]	6
H	Luminaire height	[mt]	6
l	Pole spacing	[mt]	20
Tab. R	Asphalt reflection coefficient		C2

Lm	Average luminance	[cd/mt ²]	0,43
U0	General uniformity		0,46
U1	Longitudinal uniformity		0,66
Ti%	Debilitating glare	[%]	6,64
SR	Surround		0,5

WL24			
N.LED	Luminaire LED number		24
P	Luminaire power consumption	[W]	24
Fi	Luminaire luminous flux	[lm]	1850

Emed	Average illumination	[lux]	7
Emin/Emed	Illumination uniformity		0,67

Lighting category satisfied			ME6
-----------------------------	--	--	-----

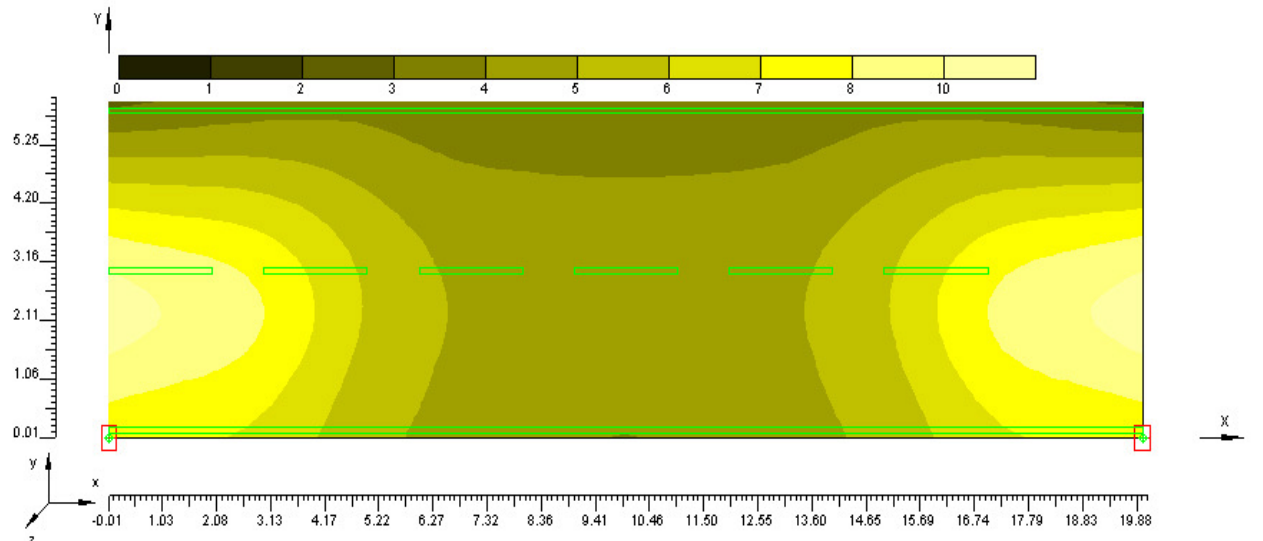
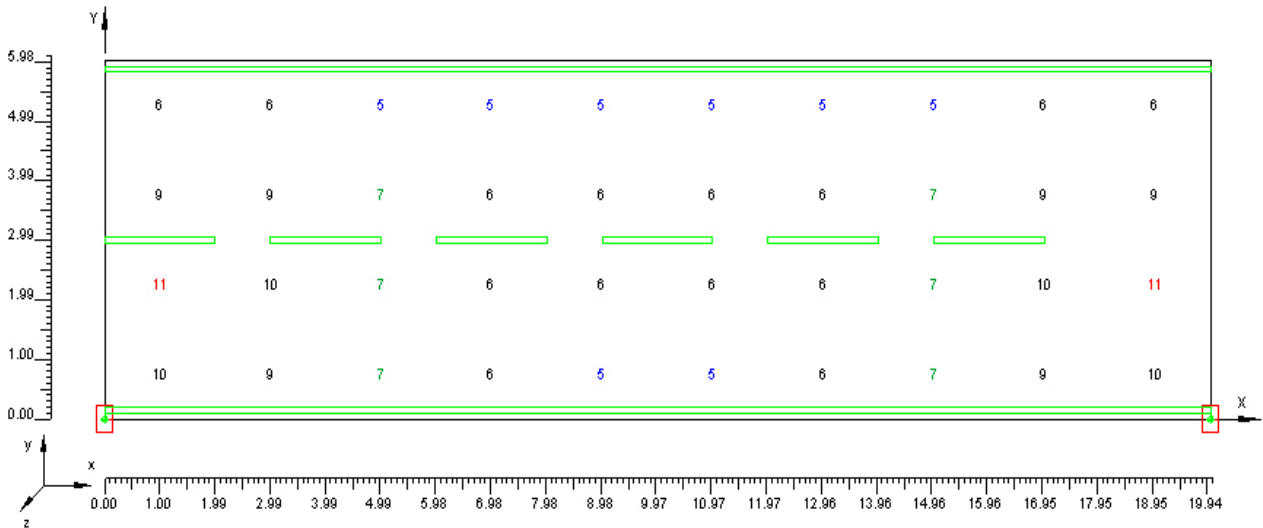

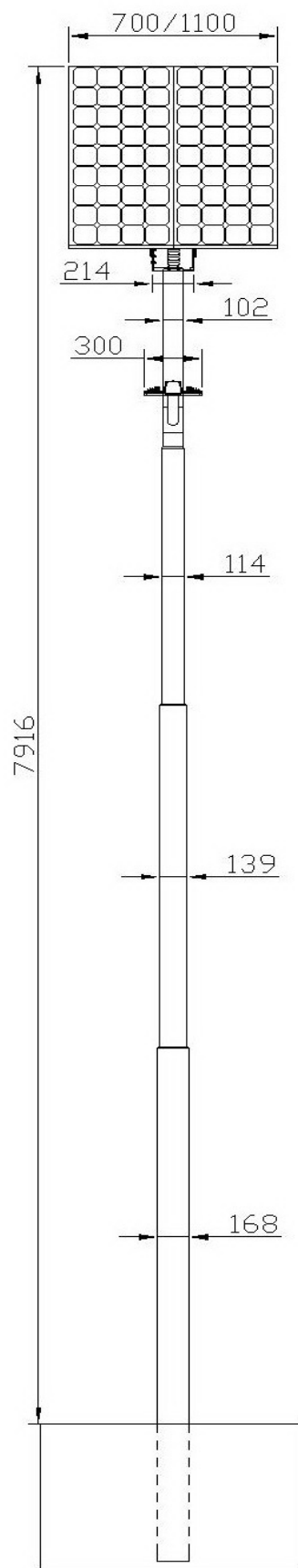
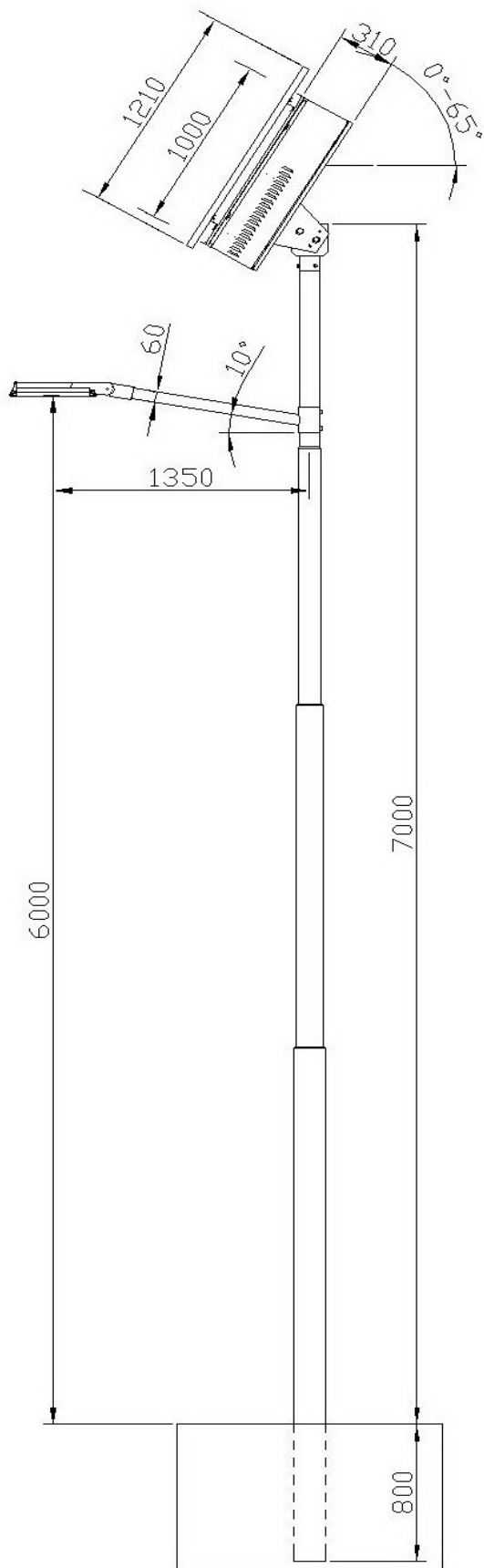

BASEMENT

The study and the calculation of the size of the plinth for the fixing of the PV street-lamp must be made by the system designer and must take into consideration the soil type and location of the installation. In the entered data there are standard indications.

MINIMUM CEMENT BASEMENT (You must design the plinth by the type of soil in the place of installation) .

FOUNDATIONS - MINIMUM PLINTH

- Concrete casting with typical resistance $R_{ck}=250$ daN/cm² reinforced with reinforcing bars having an improved adhesion - steel FeB44k not controlled.
- Length of the pole inside the ground-foundations: 80cm.
- If the ground is able to absorb a long-duration tension of 0,8 - 1,0 daN/cm² and very short-duration tensions of 1,4 - 1,8 daN/cm² there is no need of sub-foundations. Instead, if the ground has a quality, you have to cast under the plinth a layer of lean clay (magrone) enough large to bring back the tension on the ground within the limit values.
- Stresses at the bottom of the standard pole (Trieste - Italy with $c_t = 1$) in all directions: $N = 250$ daN (Normal effort); $M = 2167$ daN m bending moment, $V = 351$ daN (cut).

The dimensioning is valid for any Italian place (including the zone 8 of Trieste), with roughness class D (open countryside), for topography coefficients $c_t = 1$ (ordinary situations).

- In case of exceptional situations such as hilly crests or mountains the foundation will be properly increased

